



**PW-275-SK**

### Single EMAG Lock

#### Overview:

600lbs EM locks were designed to meet fire/life safety applications by providing an auxiliary locking mechanism that has no moving parts to bind or wear out for trouble free operation. This will ensure inhibited release at all times where they have become extremely prevalent in applications other than fire/life safety. Suitable for access controlled & secure areas within buildings.

#### Features:



Life Safety Applications



Zero Residual Magnetism



Low Energy Consumption



Cost Savings



12/24Vdc Selectable



Ideal for all door type

#### Extended Features:

- » Additional feature with LED Lens to ease the Specification monitoring of Lock Status.
- » Lock Status Monitoring
- » Electroless Nickel (EN) Plated Armature Plate
- » Anodized Aluminium Housing
- » CE Compliance

## SPECIFICATIONS:

PW275-SK	
<b>Holding Force</b>	Up to 600lbs
<b>Magnet Size</b>	250 X 42 X 26 mm
<b>Armature Size</b>	180 X 38 X 11 mm
<b>Current Drain</b>	480mA±10%/12Vdc 240mA±10%/24Vdc
<b>Operating Temperature</b>	(-10 to 55)°C (14 to 131)°F
<b>Est. Weight</b>	2.0 kg

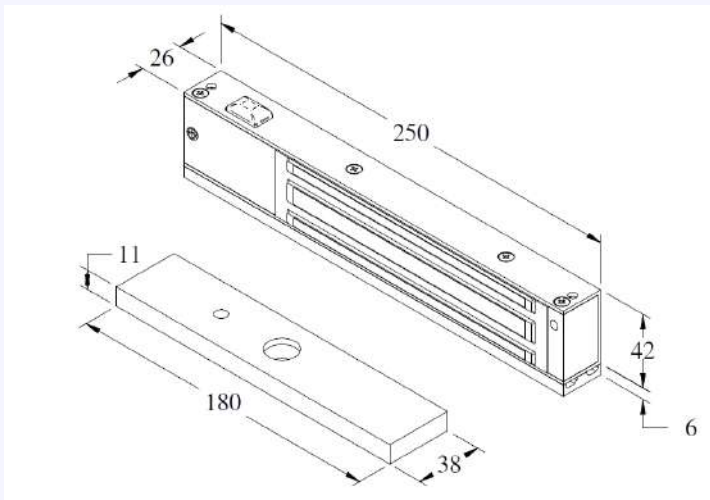

## WIRING DIAGRAM

